

ARP ODYSSEY

PROPORTIONAL PITCH CONTROL (PPC) MODIFICATION KIT

(Models 2810 - 2813)

ITEM NO.	ARP PART NO.	DESCRIPTION	QTY.
1	1200301	Diode 1N4148	3
2	1000430	Resistor 2.2K	1
3	1000438	Resistor 10K	1
4	1000451	Resistor 100K	1
5	7217301	P.C. Board Assy.	1
6	7522401	Button Assy.	1
7	4705301	Cover	1
8	5203601	Spacer	1
9	2300509	Screw 2-56	4
10	2306201	Washer Int. lock	4
11	2307001	Hex nut 2-56	4
12	5204601	Template	1

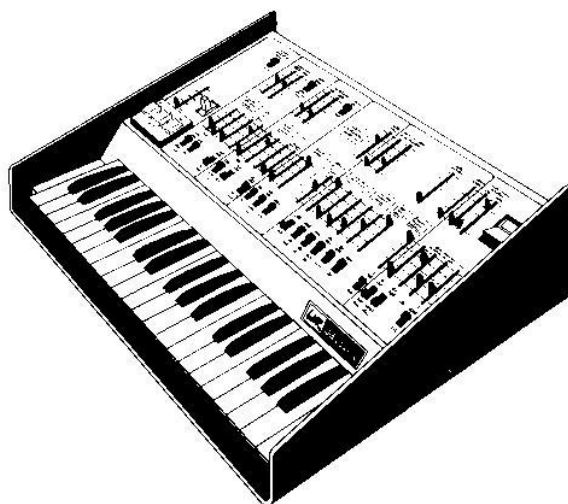

ARP INSTRUMENTS, INC.
45 Hartwell Avenue
Lexington, MA 02173
(617) 861-6000

Document No. 9002201
Kit No. 6800301

WWW.BLEEPS-AND-PEEPS.COM

STEP 1 P.C. BOARD REMOVAL

- A. Remove Odyssey bottom cover by removing all bottom screws and the three screws located on each side.
- B. Remove pitch bend knob with an allen wrench.
- C. Place unit upside down on a protective foam mat with the keyboard facing you; as shown in Fig. 1-1.
- D. Remove keyboard and Interconnect Board.
- E. Board All can be completely removed by removing the five screws indicated in Fig. 1-1.

1-1

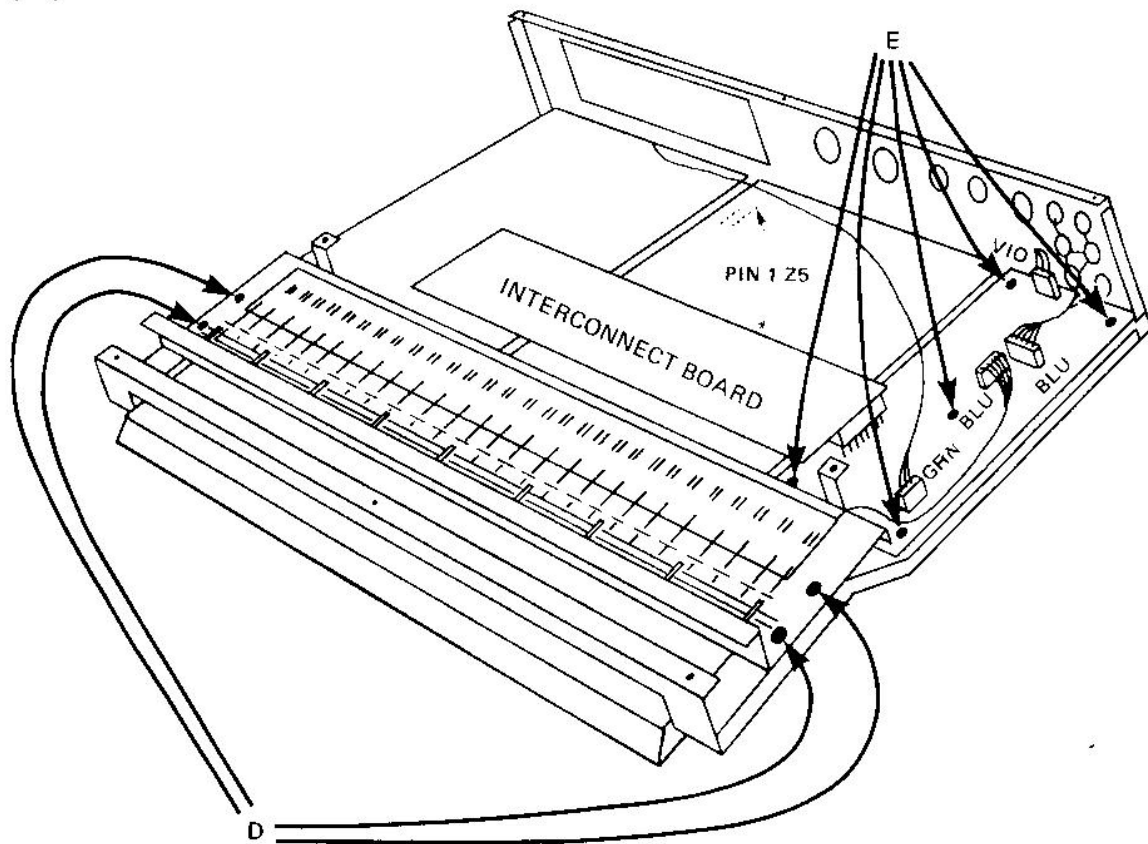

STEP 2 BOARD A11 REWORK

- Refer to Fig. 2-1 (Board A11 layout) and remove the following components; R26, R27, R29.
- Locate diodes CR3 and CR4 and remove only one side from the P.C. board. Refer to the junction indicated in Fig. 2-1.
- Solder the two other diodes supplied with this kit to the ends of the diodes that were removed from the P.C. board. Insure that the polarity remains in the same direction as shown on the completed reworked layout in Fig. 2-2.
- Resolder the remaining diode ends to point B (Fig. 2-1).
- Replace R26 that was removed with a 100K resistor.
- Solder a 10K resistor as shown in Fig. 2-2.
- Solder a 2.2K resistor as shown in Fig. 2-2.
- Do not remount Board A11 until Step No. 3 has been completed.

2-1

A
COMPONENT SIDE VIEW

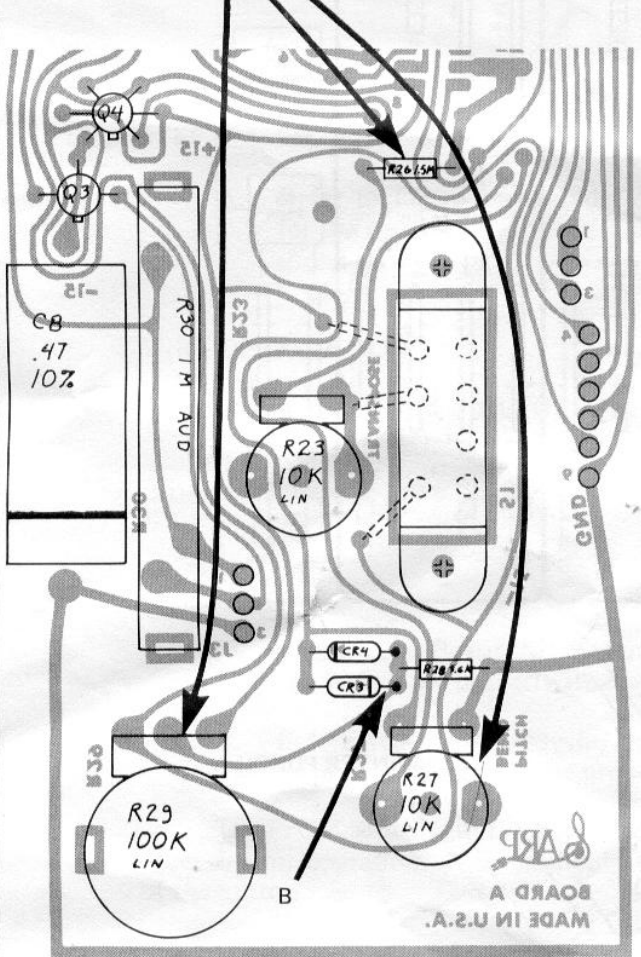

2-2

E
COMPONENT SIDE VIEW

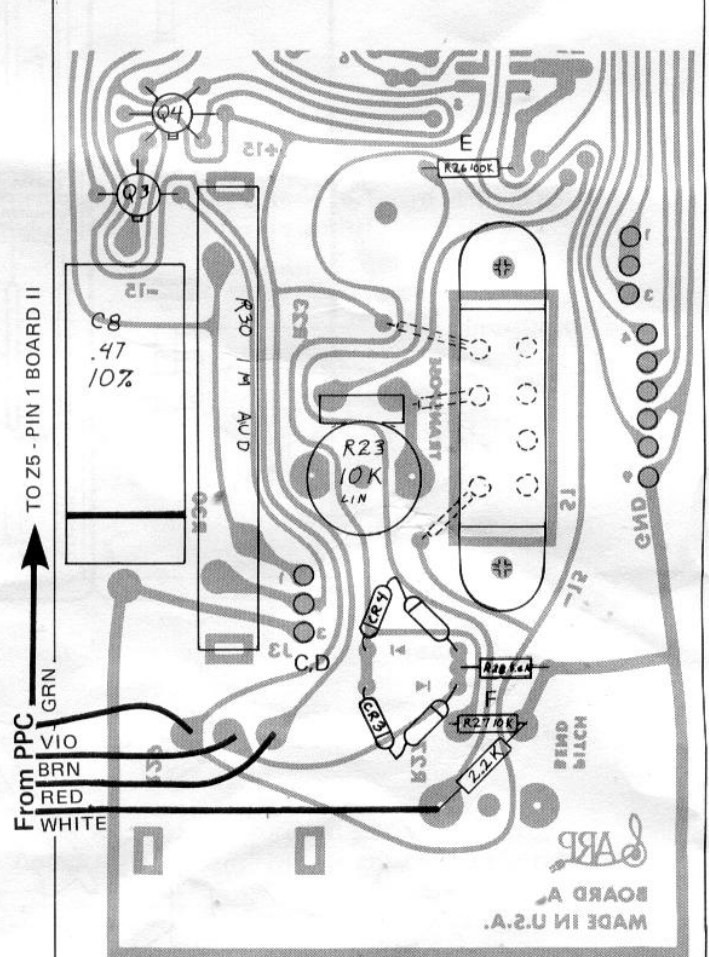

*Note; An extra diode is supplied with this kit in the event of accidental break-age.

STEP 3 CHASSIS DRILLING AND ASSEMBLY

- A. Refer to Fig. 3-1.
- B. Align the holes on the locating template with the Odyssey chassis holes.
- C. To insure the template is kept stationary, insert a pen or sharpened pencil in the alignment holes; then mark the four holes for drilling (Fig. 3-2).
NOTE: It may be necessary to center punch the drill holes "off center" for model Odysseys that used the EPOXIED P.C. BOARD STUDS instead of the more commonly used INLAID MOUNTS. This assures proper mounting clearance.
- D. Remove template.
- E. Drill holes using a No. 31 (.120) drill bit.
- F. Insure all iron filings are removed and refer to Fig. 3-3 for proper PPC installation.

3-1

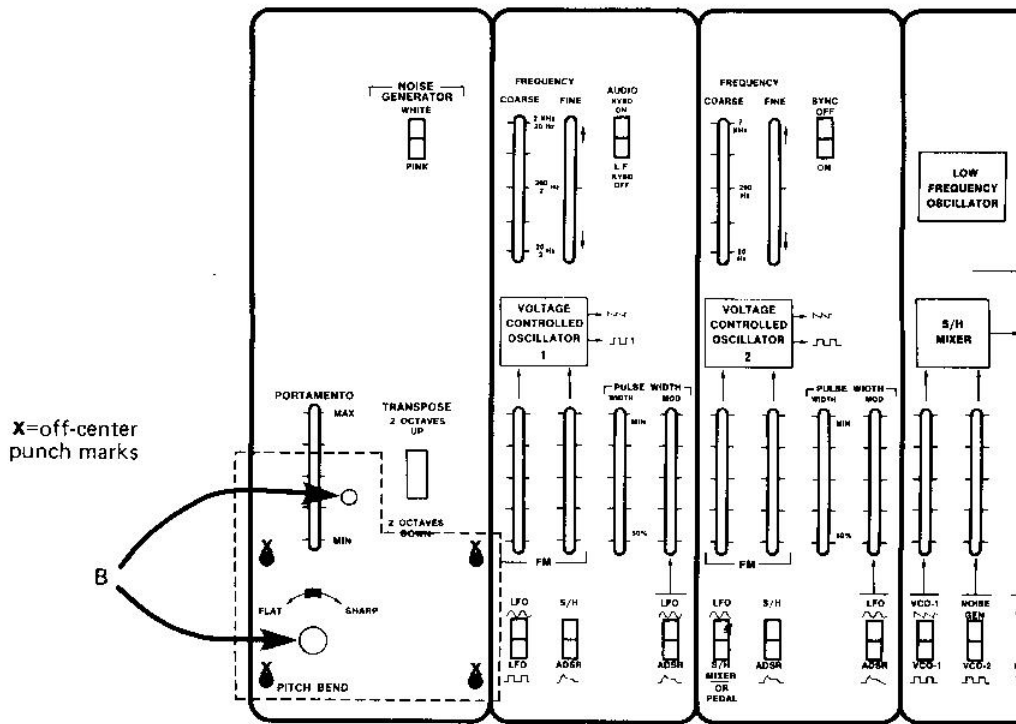

3-2

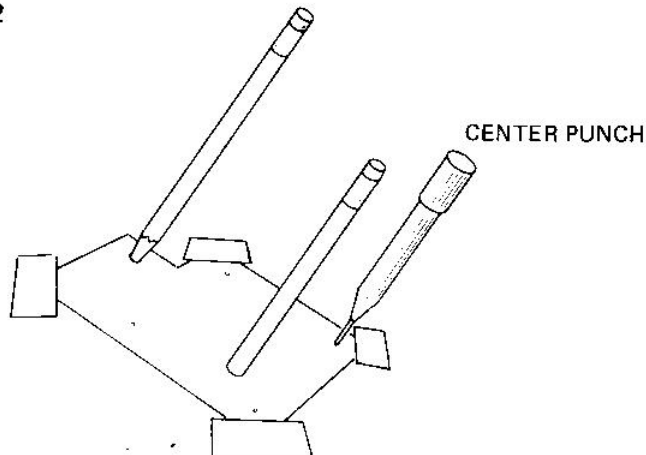

NOTE: Do not over-tighten screws.

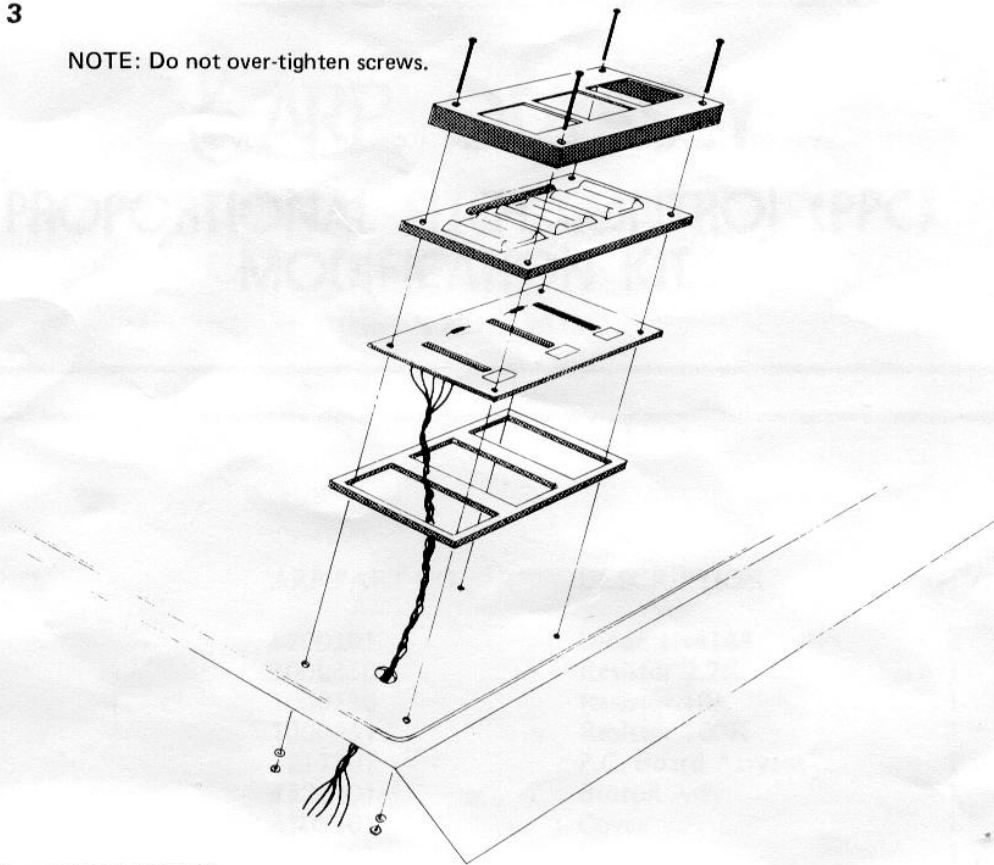

STEP 4 PPC WIRING

- A. Refer to Fig. 2-2 and solder colored wires from PPC unit to Board AII except for the green wire which is soldered to pin 1 of Z5 on Board BII.

WIRE DESIGNATION

Green to pin 1 Z5, Board BII(LFO).
 Red to +15V Supply.
 Violet to -15V Supply.
 Brown to junction of new diodes and R28.
 White to junction of R26 and R27.

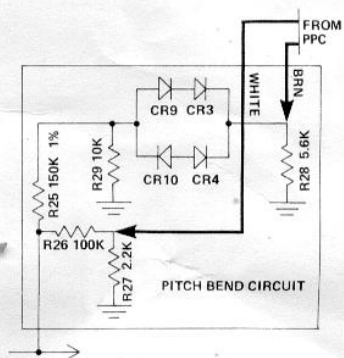

STEP 5

- A. Reassemble Board AII, Interconnect Board, and Keyboard. Insure that all connectors are properly fitted.
- B. Before reinstalling Odyssey bottom cover, place unit right side up on a flat surface and check for the proper operation of PPC.

The PPC is added with the keyboard control voltage; therefore, no special settings are necessary for operation. Also, it should be noted that the sensitivity is greatest at the top of the button.

Button Controller

Approximate Maximum Sensitivity

Sharp	5 semitones
Vibrato	3 semitones
Flat	4 semitones